

# Mid-Hinged Columns

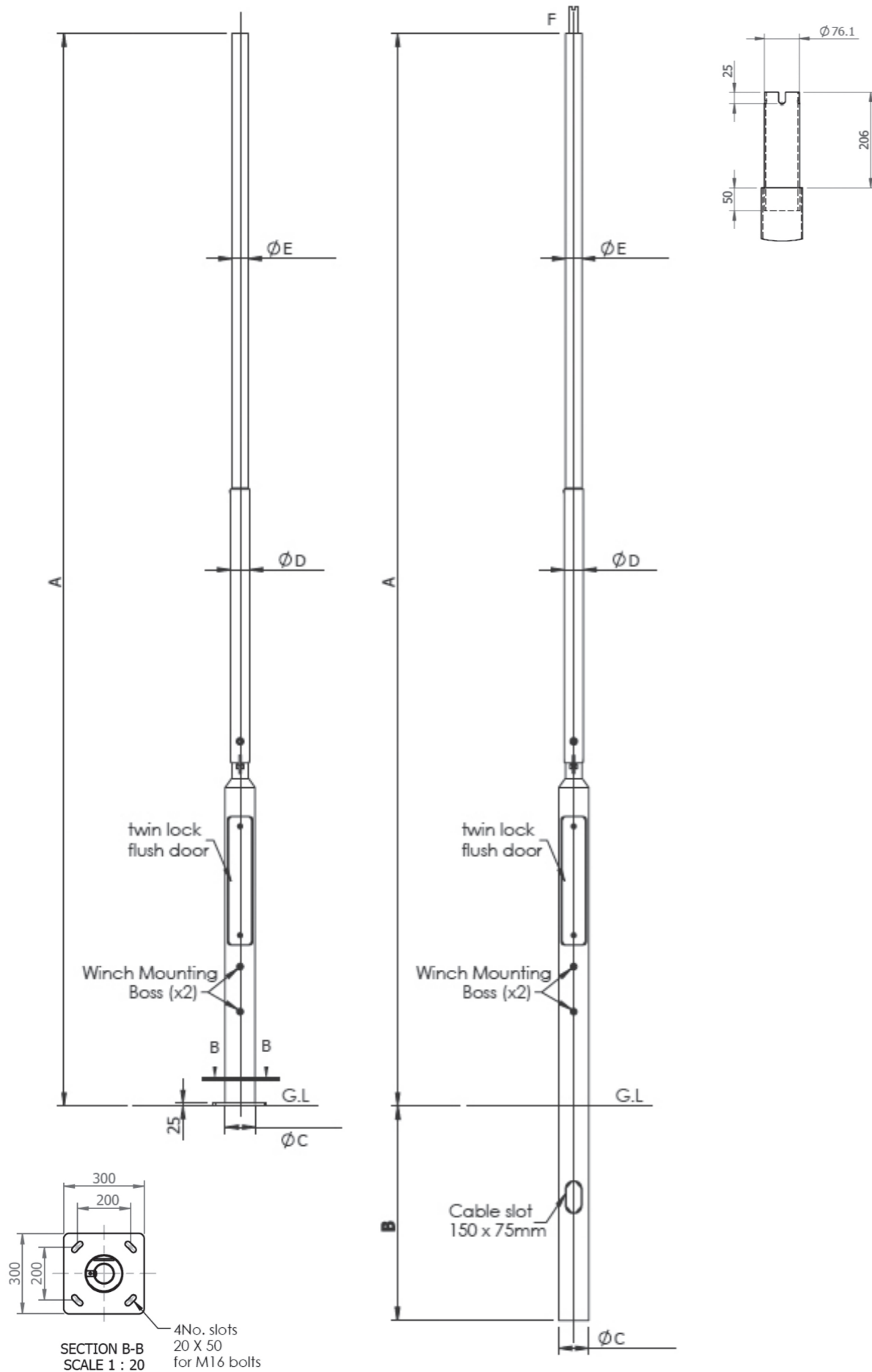

## PRODUCT DATA

### CRBH - ROOT MOUNTED BASE-HINGED

Product code	A (M)	B (MM)	C (MM)	D (MM)	E (MM)	DOOR APERTURE	MAX HEAD LOAD (Kg/M <sup>2</sup> )*
712.CRMH4M	4	1000	140	89	76	600 x 115	50 / 0.50
712.CRMH5M	5	1000	140	89	76	600 x 115	45 / 0.39
712.CRMH6M	6	1000	140	89	76	600 x 115	30 / 0.20

### INTEGRAL REDUCER (SECTION F)

712.CRMH8M	7.7	1200	168	101	89	600 x 115	30 / 0.25
------------	-----	------	-----	-----	----	-----------	-----------

### CFBH - FLANGE PLATED BASE-HINGED

Product code	A (M)	B (MM)	C (MM)	D (MM)	E (MM)	DOOR APERTURE	MAX HEAD LOAD (Kg/M <sup>2</sup> )*	HOLE CENTRE	BOLTS
712.CFMH4M	4	N/A	140	89	76	600 x 115	50 / 0.50	200 x 200	M16
712.CFMH5M	5	N/A	140	89	76	600 x 115	45 / 0.39	200 x 200	M16
712.CFMH6M	6	N/A	140	89	76	600 x 115	30 / 0.20	200 x 200	M16

### INTEGRAL REDUCER (SECTION F)

712.CFMH8M	7.7	N/A	168	101	89	600 x 115	30 / 0.25	300 x 300	M24
------------	-----	-----	-----	-----	----	-----------	-----------	-----------	-----

## PRODUCT DESCRIPTION

High-quality general-purpose tubular MID-HINGED galvanised steel columns. Available in root mounted or flanged plated, for floodlight or lantern brackets, static or hinged also paint options available.

Constructed from mild steel and root externally bitumen coated as standard. Full range of brackets and spigots available.

NOTE - Raise and lowering equipment may be required. Please ask for details before ordering.

Columns manufactured to BSEN40, PD6547:2004+A1:2009

Extra heavy wind loading region (no sign)

Load B/Deflection class3

As the choice of columns depends on many factors including the area of installation, weight and windage of both bracket(s) and luminaire(s) we need to ascertain these details before choosing a column type.

\*Maximum design head load based on wind loading region with operation of bracket/luminaire(s) being on the same plane as door.